

**SSC MOCK TEST - 409 (SOLUTION)**

1. (1) As,  $65 \Rightarrow 6^3 - 5^3 = 91$   
 Similarly,  $96 \Rightarrow 9^3 - 6^3 = 513$
2. (2) Court is the place where Tennis is played, while Ring is the place where Boxing is played.

3. (4) (1)  $138 \Rightarrow \frac{1+3+8}{3} = 4$                       (2)  $480 \Rightarrow \frac{4+8+0}{3} = 4$   
 (3)  $921 \Rightarrow \frac{9+2+1}{3} = 4$                       (4)  $747 \Rightarrow \frac{7+4+7}{3} = 6$

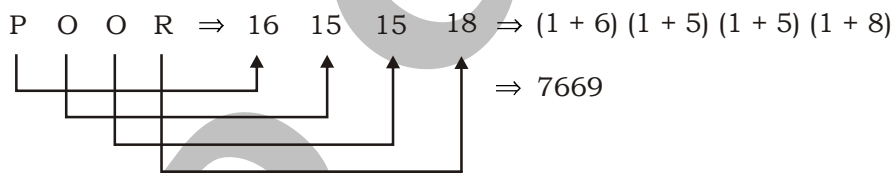
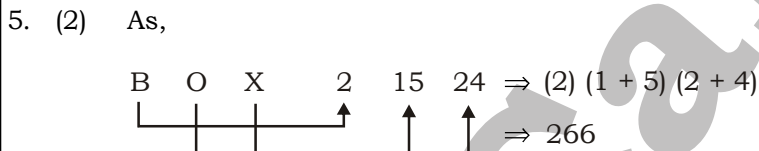
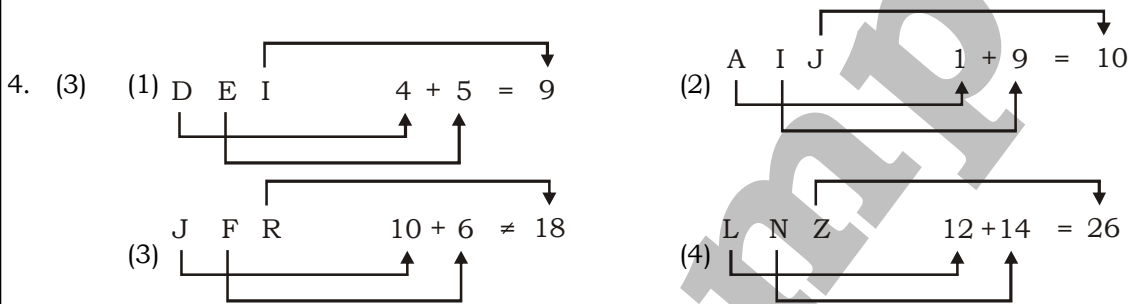

Similarly,

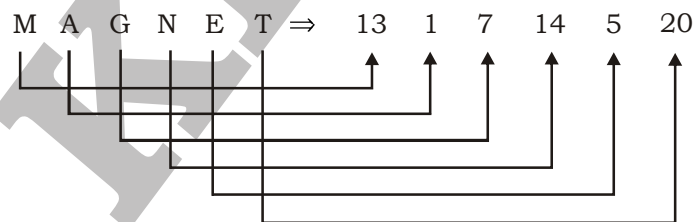

$\Rightarrow (1 + 3) (1) (7) (1 + 4) (5) (2 + 0)$

$\Rightarrow 417552$

6. (1)  $24 \times \frac{3}{2} = 36$

$36 \times \frac{3}{2} = 54$

$54 \times \frac{3}{2} = 81$

$81 \times \frac{3}{2} = \frac{243}{2}$

7. (3)

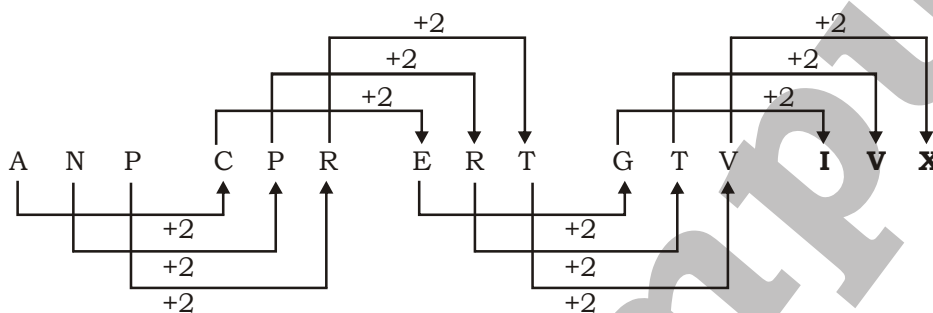

8. (1)

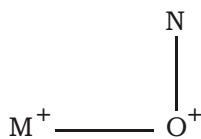

Hence, M is the son of N.

9. (4) As,  $121 \Rightarrow (1 + 2 + 1)^2 = 16$

$16 \Rightarrow (1 + 6)^2 = 49$

Similarly,  $312 \Rightarrow (3 + 1 + 2)^2 = 36$

$36 \Rightarrow (3 + 6)^2 = 81$

10. (2) idmkj/idmkj/idmkj/idmkj

11. (2)

12. (3) **In first row,**

$24 + (2 + 4) = 30$

$30 + (3 + 0) = 33$

**In second row,**

$38 + (3 + 8) = 49$

$49 + (4 + 9) = 62$

**In third row,**

$41 + (4 + 1) = 46$

$46 + (4 + 6) = 56$

13. (2)  $125 \div 25 \times 4 + 3 - 5 = 78$

After Changing the numbers 25 and 5 to each other,

$125 \div 5 \times 4 + 3 - 25 = 78$

$25 \times 4 + 3 - 25 = 78$

$103 - 25 = 78$

$78 = 78$

14. (1)

Day	Teacher	Subject
Monday	Kartik	Social Science
Tuesday	Lakhan	Arts
Wednesday	Jemmy	Science
Thursday	Mohan	English
Friday	Onkar	Mathematics
Saturday	Neeraj	Hindi

Hence, Hindi is taught on Saturday.

15. (2) 4. Uttar Pradesh → 2. Madhya Pradesh → 1. Andhra Pradesh → 5. Himachal Pradesh →  
3. Arunachal Pradesh

16. (3)

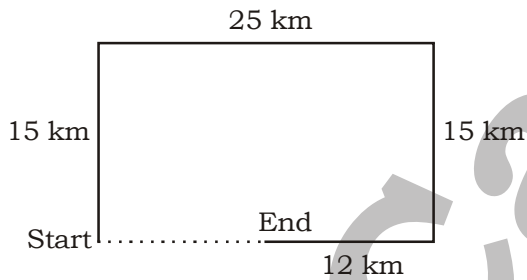

Hence, the distance between starting point and end point is 13 km.

17. (2)

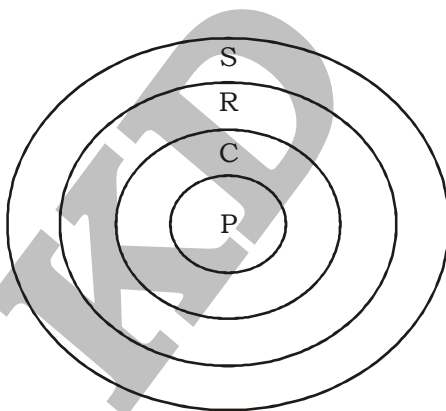

I. True    II. Doubt    III. Doubt    IV. True

Hence, only conclusions I and IV follow.

18. (3)

19. (2)

20. (4)

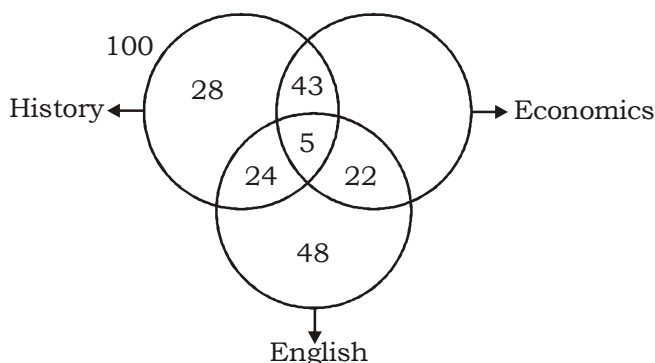

Number of students passed in History and Economics =  $100 - (28 + 5 + 24) = 43$

Hence, Number of students passed in Economics only

$$= 200 - (28 + 43 + 5 + 24 + 22 + 48)$$

$$= 200 - 170 = 30$$

21. (1)

Total ages of A, B and C =  $28 \times 3 = 84$  years

Total ages of A, B, C and D =  $26 \times 4 = 104$  years

Age of D =  $104 - 84 = 20$  years

Age of E =  $20 + 2 = 22$  years

Total ages of B, C, D and E =  $22 \times 4 = 88$  years

Total ages of B, C and D =  $88 - 22 = 66$  years

$\therefore$  Age of A =  $104 - 66 = 38$  years

22. (1)

23. (2)

24. (1)

25. (4)

26. (4)

The first Sayyid ruler of Delhi was Khizr Khan (reigned 1414–21), who had been governor of the Punjab.

27. (2)

Arunachal Pradesh is the most northeastern one of India. China and Arunachal Pradesh share a border, which is called McMahon Line. Also, the Republic of China claims a large part of the state.

28. (2)

PM Narendra Modi is a 2019 Hindi-language biographical drama film directed by Omung Kumar, and written by Anirudh Chawla and Vivek Oberoi. The film is jointly produced by Suresh Oberoi, Sandip Ssingh, Anand Pandit, Acharya Manish under the banner of Legend Studios.

29. (3)

Distillation is a process involving the conversion of a liquid into a vapor that is subsequently condensed back to liquid form. In distillation both vaporization and Condensation take place.

30. (4)

Galena, also called lead glance, is the natural mineral form of lead(II) sulfide (PbS). It is the most important ore of lead and an important source of silver.

32. (3)

Panchavati, or modern-day Nashik, is a city that is entirely in the state of Maharashtra. It is very crucial among the places visited by Lord Rama as it is where the crucial phase of his exile occurs. The entire Aranya Kanda of Ramayana is set in Panchavati.

33. (2)

Rani-ki-Vav (the Queen's Stepwell) at Patan, Gujarat - UNESCO World Heritage Centre.

35. (2)

Union Cabinet has declared August 23 as 'National Space Day' to commemorate Chandrayaan-3's successful landing on the Moon.

37. (4)

Paan Singh Tomar (1932 – October 1, 1981) was an Indian athlete and a seven-time national steeplechase champion during the 1950s and 1960s. He represented India at the 1958 Asian Games in Tokyo, Japan.

38. (4)

Google was incorporated as a privately-held company on 4 September 1998, by founders Larry Page and Sergey Brin.

40. (4) Amortization can refer to the process of paying off debt over time in regular installments of interest and principal sufficient to repay the loan in full by its maturity date.
41. (1) Gamma rays have the highest frequency in the electromagnetic spectrum. They have a frequency of the order of about  $10^{20}$  to  $10^{22}$  Hz.
44. (1) West Bengal, Assam and Bihar are the major jute growing states in the country, which accounts for about 98 percent of the country's jute area and production (State of Indian Agriculture, 2016-2017).
45. (1) Osteoporosis causes bones to become weak and brittle — so brittle that a fall or even mild stresses such as bending over or coughing can cause a fracture. Osteoporosis-related fractures most commonly occur in the hip, wrist or spine. Bone is living tissue that is constantly being broken down and replaced.
47. (3) Buoyancy is the upward force that acts on the swimmer while they are in the water. The pressure from beneath the swimmer is much greater than the pressure above them which allow the swimmer to float.
48. (4) Calcium hydroxide, also called slaked lime,  $\text{Ca(OH)}_2$ , is obtained by the action of water on calcium oxide.

51. (1) Let the CP of 1 litre milk = ₹100  
 SP of 1 litre milk = ₹100  
 Profit = 25%  
 By alligation method,

Milk	Water
100	0
$\frac{100}{1.25}$	
$\frac{100}{1.25} - 0$	$100 - \frac{100}{1.25}$

Ratio = 80 : 20 = 4 : 1

∴ Required ratio = 4 : 1

52. (3) (A + B)'s 1 day work =  $\frac{1}{20}$

C's 1 day work =  $\frac{1}{40}$

(A + B + C)'s 1 day work =  $\frac{1}{20} + \frac{1}{40} = \frac{2+1}{40} = \frac{3}{40}$  .....(i)

A's 1 day work = (B + C)'s 1 day work .....(ii)

From (i) and (ii), we get

$2 \times (\text{A's 1 day work}) = \frac{3}{40}$

Therefore, A's 1 day work =  $\frac{3}{80}$

B's 1 day work =  $\frac{1}{20} - \frac{3}{80} = \frac{1}{80}$

∴ B alone can do the same work in 80 days.

53. (3) Let the five consecutive odd number be  $x, x + 2, x + 4, x + 6$  and  $x + 8$ .

ATQ,

$$x + x + 2 + x + 4 + x + 6 + x + 8 = 155$$

$$5x + 20 = 155$$

$$5x = 135$$

$$x = 27$$

$$\text{Highest number} = 27 + 8 = 35$$

$$\text{Lowest number} = 27$$

$$\therefore \text{Required product} = 35 \times 27 = 945$$

54. (4) Let the capacity of tank = 36 litres

$$\text{Pipe A fill the tank in 1 hour} = \frac{36}{6} = 6 \text{ litres/hour}$$

$$\text{Pipe B fill the tank in 1 hour} = \frac{36}{12} = 3 \text{ litres/hour}$$

$$\text{Pipe C fill the tank in 1 hour} = \frac{36}{18} = 2 \text{ litres/hour}$$

$$\text{For 36 minutes the pipe B and C can fill} = (3 + 2) \times \frac{36}{60} = 3 \text{ litres}$$

$$\text{Remaining capacity} = 36 - 3 = 33 \text{ litres}$$

$$\text{Time required to fill the remaining part} = \frac{33}{11} = 3 \text{ hours}$$

$$\therefore \text{Required total time} = 3 \text{ hours } 36 \text{ minutes}$$

55. (3) Let each quantity of each sample = 100 units

$$\text{Quantity of milk in first sample} = 100 \times \frac{35}{100} = 35 \text{ units}$$

$$\text{Quantity of milk in second sample} = 100 \times \frac{75}{100} = 75 \text{ units}$$

$$\text{Quantity of milk in mixture} = 35 \times \frac{85}{100} + 75 \times \frac{15}{100} = 29.75 + 11.25 = 41 \text{ units}$$

$$\therefore \text{Required percentage of milk in the mixture} = \left( \frac{41}{100} \times 100 \right) \% = 41\%$$

56. (2)  $\frac{3}{4} \times 2 \frac{2}{3} \div \frac{5}{9}$  of  $1 \frac{1}{5} + \frac{2}{23} \times 3 \frac{5}{6} \div \frac{2}{7}$  of  $2 \frac{1}{3}$

$$= \frac{3}{4} \times \frac{8}{3} \div \frac{5}{9}$$
 of  $\frac{6}{5} + \frac{2}{23} \times \frac{23}{6} \div \frac{2}{7}$  of  $\frac{7}{3}$

$$= \frac{3}{4} \times \frac{8}{3} \div \frac{2}{3} + \frac{2}{23} \times \frac{23}{6} \times \frac{3}{2}$$

$$= 3 + \frac{1}{2} = 3 \frac{1}{2}$$

57. (3)  $\triangle ABC$  is right angled triangle, right angle at B.

So AC is the hypotenuse.

$$AC - AB = 1 \text{ (Given).....(i)}$$

By Pythagoras theorem,

$$AC^2 = AB^2 + BC^2$$

$$BC^2 = AC^2 - AB^2$$

$$7^2 = (AC - AB)(AC + AB)$$

$$49 = 1(AC + AB)$$

$$AC + AB = 49 \quad \text{.....(ii)}$$

Adding (i) and (ii) we get,

$$2AC = 50$$

$$AC = 25 \text{ cm}$$

Substitute the value of AC in equation (ii), we get

$$AB = 24 \text{ cm}$$

$$\text{Now, } \cos A + \sin A = \frac{AB}{AC} + \frac{BC}{AC} = \frac{24}{25} + \frac{7}{25} = \frac{31}{25}$$

$$\therefore \cos A + \sin A = \frac{31}{25}$$

58. (1) Curved surface area of a cylinder =  $2\pi rh = 254 \text{ m}^2$  .....(i)

$$\text{Volume of cylinder} = \pi r^2 h = 1778 \text{ m}^3 \quad \text{.....(ii)}$$

Divide equation (ii), by (i), we get

$$\frac{\text{Volume of cylinder}}{\text{CSA of cylinder}} = \frac{1778}{254}$$

$$\frac{\pi r^2 h}{2\pi rh} = \frac{1778}{254}$$

$$\frac{r}{2} = 7$$

$$r = 7 \times 2 = 14 \text{ cm}$$

$$\text{Diameter} = 14 \times 2 = 28 \text{ cm}$$

Put the value of r in equation (i),

$$2\pi rh = 254$$

$$2 \times \frac{22}{7} \times 14 \times h = 254$$

$$h = \frac{254}{88} = 3 \text{ cm}$$

$\therefore$  Required ratio = 28 : 3

59. (2)

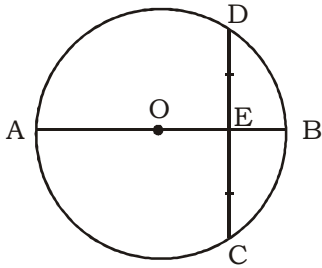

Let the radius of circle be  $r$  cm.

So,  $OC = OD = r$  cm

As,  $OB = OE + EB$

$r = OE + 6$  (since  $OB$  is the radius and  $EB = 6$  cm given)

$OE = (r - 6)$  cm

We know that if a line drawn from the centre to the chord, it bisects the chord, and then it is perpendicular to the chord.

Hence,

$OE \perp CD$

In  $\triangle OED$ ,

$$OE^2 + ED^2 = OD^2$$

$$(r - 6)^2 + 12^2 = r^2$$

$$r^2 + 36 - 12r + 144 = r^2$$

$$12r = 180$$

$$r = \frac{180}{12} = 15 \text{ cm}$$

$\therefore$  Radius of circle = 15 cm

60. (2) Total number of families whose monthly expenditure on food is ₹2800 or more, but below ₹4500 =  $40 + 55 + 68 + 50 + 43 = 256$

Total number of families whose monthly expenditure on food are ₹3200 or more but below ₹4800 =  $55 + 68 + 50 + 43 + 41 = 257$

$$\therefore \text{Required less\%} = \left( \frac{1}{257} \times 100 \right) = 0.38\%$$

61. (3)

$$\begin{aligned} & \frac{\cot \theta}{(1 - \sin \theta)(\sec \theta + \tan \theta)} \\ &= \frac{\frac{\cos \theta}{\sin \theta}}{(1 - \sin \theta) \left( \frac{1}{\cos \theta} + \frac{\sin \theta}{\cos \theta} \right)} \\ &= \frac{\frac{\cos \theta}{\sin \theta}}{(1 - \sin \theta) \left( \frac{1 + \sin \theta}{\cos \theta} \right)} \\ &= \frac{\cos^2 \theta}{\sin \theta (1 - \sin^2 \theta)} \\ &= \frac{\cos^2 \theta}{\sin \theta \times \cos^2 \theta} = \frac{1}{\sin \theta} \end{aligned}$$



62. (4)

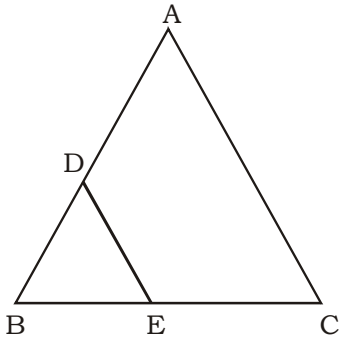

$$\frac{AD}{DB} = \frac{5}{3} \quad (\text{Given})$$

$$\frac{AD}{DB} + 1 = \frac{5}{3} + 1$$

$$\frac{AD + DB}{DB} = \frac{5 + 3}{3}$$

$$\frac{AB}{DB} = \frac{8}{3} \quad \dots(i)$$

In  $\triangle BDE$  and  $\triangle ABC$ ,

$$\angle B = \angle B \quad (\text{Common})$$

$$\angle BAC = \angle BDE \quad [\because DE \parallel AC]$$

So,

$$\triangle ABC \sim \triangle BDE \quad (\text{By AA similarity criteria})$$

Now,

$$\frac{\text{ar.}(\triangle ABC)}{\text{ar.}(\triangle BDE)} = \frac{AB^2}{DB^2} = \frac{8^2}{3^2} = \frac{64}{9}$$

$$\therefore \text{ar.}(\triangle ABC) : \text{ar.}(\triangle BDE) = 64 : 9$$

63. (3) Let the length of second train be  $x$  m.

$$\text{Relative speed} = 60 - 33 = 27 \text{ km/hr} = 27 \times \frac{5}{18} = 7.5 \text{ m/s}$$

ATQ,

$$\frac{350 + x}{7.5} = 120$$

$$350 + x = 900$$

$$\therefore x = 900 - 350 = 550 \text{ m}$$

64. (3) Simple interest = ₹5880

Rate = 10%

$$\text{Time} = 3\frac{1}{2} \text{ years} = \frac{7}{2} \text{ years}$$

$$\text{Principal} = \frac{5880 \times 100 \times 2}{10 \times 7} = ₹16800$$

Now, Principal = ₹16800

Rate = 10%

$$\text{Time} = 2\frac{1}{2} \text{ years}$$

$$A = 16800 \left(1 + \frac{10}{100}\right)^2 \left(1 + \frac{5}{100}\right)$$

$$A = 16800 \times \frac{11}{10} \times \frac{11}{10} \times \frac{21}{20} = ₹21344.40$$

∴ Compound interest = 21344.40 - 16800 = ₹4544.40

65. (2) Let p = 6, q = 5, r = 7

LCM of (6, 5, 7) = 210 and HCF = 1

$$mn = 210 \times 1 = 210$$

$$\text{and } pqr = 6 \times 5 \times 7 = 210$$

∴ mn = pqr

66. (1)  $\sin^4 \theta + \cos^4 \theta = 2\sin^2 \theta \cdot \cos^2 \theta$

$$\sin^4 \theta + \cos^4 \theta - 2\sin^2 \theta \cdot \cos^2 \theta = 0$$

$$(\sin^2 \theta - \cos^2 \theta)^2 = 0$$

$$\sin^2 \theta = \cos^2 \theta$$

$$\sin \theta = \cos \theta$$

$$\frac{\sin \theta}{\cos \theta} = 1$$

∴ tan θ = 1

67. (3)

$$\begin{array}{|c|} \hline \text{M : W} \\ \hline 5 : 2 \\ \hline 300 \text{ l} \\ \hline \end{array} \quad \begin{array}{|c|} \hline \text{M : W} \\ \hline 4 : 1 \\ \hline 200 \text{ l} \\ \hline \end{array} \quad \begin{array}{|c|} \hline \text{M : W} \\ \hline 4 : 1 \\ \hline 100 \text{ l} \\ \hline \end{array}$$

$$1^{\text{st}} 300 \times \frac{1}{3} = 100 \rightarrow \text{water} = \frac{2}{7} \times 100 = \frac{200}{7}$$

$$2^{\text{nd}} 200 \times \frac{1}{2} = 100 \rightarrow \text{water} = \frac{1}{5} \times 100 = 20$$

$$3^{\text{rd}} 100 \times \frac{1}{7} = \frac{100}{7} \rightarrow \text{water} = \frac{1}{5} \times \frac{100}{7} = \frac{100}{35} = \frac{20}{7}$$

$$\text{Total water} = \frac{200}{7} + \frac{20}{7} + 20 = \frac{360}{7}$$

$$\text{Total mixture} = 100 + 100 + \frac{100}{7} = \frac{1500}{7}$$

$$\therefore \text{Required percentage} = \left( \frac{\frac{360}{7}}{\frac{1500}{7}} \times 100 \right) \% = 24\%$$

68. (4)  $\frac{M_1 D_1 T_1}{W_1} = \frac{M_2 D_2 T_2}{W_2}$

$$\frac{12 \times 6 \times 240}{460} = \frac{18 \times 360 \times 8}{W_2}$$

$$\therefore W_2 = 1380$$

69. (1)  $[(0.87)^2 + (0.13)^2 + (0.87) \times (0.26)]^{2013}$   
 $[(0.87)^2 + (0.13)^2 + 2(0.87) \times (0.13)]^{2013}$   
 $[(0.87 + 0.13)^2]^{2013}$   
 $[1^2]^{2013} = 1$

70. (1)  $(a - b) = 2$

Cubing both sides,

$$(a - b)^3 = (2)^3$$

$$a^3 - b^3 - 3ab(a - b) = 8$$

$$152 - 3ab(2) = 8$$

$$-6ab = -144$$

$$ab = 24$$

$$a^3 - b^3 = 152$$

Squaring both sides,

$$(a^3 - b^3)^2 = (152)^2$$

$$a^6 + b^6 - 2a^3b^3 = 23104$$

$$\therefore a^6 + b^6 = 23104 + 2(24)^3 = 50752$$

71. (4)  $8(4M + 6F) = 10(3M + 7F)$

$$32M + 48F = 30M + 70F$$

$$2M = 22F$$

$$M : F = 11 : 1$$

$$D(10F) = 10(3M + 7F)$$

$$D(10 \times 1) = 10(3 \times 11 + 7 \times 1)$$

$$\therefore D = 33 + 7 = 40 \text{ days}$$

72. (1) Required ratio =  $(70 + 80 + 40) : (20 + 60 + 20) = 190 : 100 = 19 : 10$

73. (2) Total production in all the years together =  $(60 + 70 + 80 + 80 + 40)$  lakh = 330 lakh

$$\text{Total export in all the years together} = (20 + 30 + 60 + 70 + 20) \text{ lakh} = 200 \text{ lakh}$$

$$\therefore \text{Required difference} = (330 - 220) \text{ lakh} = 110 \text{ lakh}$$

74. (4) Difference of production and import in the year 2001 =  $(70 - 30)$  lakh = 40 lakh

$$\text{Difference of production and export in the year 2004} = (40 - 20) \text{ lakh} = 20 \text{ lakh}$$

$$\therefore \text{Required more\%} = \left( \frac{40 - 20}{20} \times 100 \right) \% = 100\%$$

75. (4) On seeing the graph, we can easily say.

$$\therefore \text{Required year is 2000, 2001, 2002 and 2004.}$$

## MEANINGS IN ALPHABETICAL ORDER

Attic	a space or room just below the roof of a building	अटारी
Avert	turn away (one's eyes or thoughts)	टालना
Broad	having an ample distance from side to side; wide	विस्तृत
Commotion	a state of confused and noisy disturbance	हल्ला गुल्ला
Condemn	express complete disapproval of, typically in public; censure	निंदा करना
Conscientious	(of a person) wishing to do what is right, especially to do one's work or duty well and thoroughly	ईमानदार
Convenience	the state of being able to proceed with something with little effort or difficulty	सुविधा
Deliverance	the action of being rescued or set free	मुक्ति
Insist	demand something forcefully, not accepting refusal	जोर देना
Liberty	the state of being free within society from oppressive restrictions imposed by authority on one's way of life, behavior, or political views	स्वतंत्रता
Lunacy	the state of being a lunatic; insanity (not in technical use)	पागलपन
Observant	quick to notice things	तेज नजर
Prevent keep	(something) from happening or arising	रोकना
Provoke	stimulate or give rise to (a reaction or emotion, typically a strong or unwelcome one) in someone	उकसाना
Recluse	a person who lives a solitary life and tends to avoid other people	वैरागी
Revere	feel deep respect or admiration for (something)	सम्मान
Rustic	relating to the countryside; rural	देहाती
Scapegoat	a person who is blamed for the wrongdoings, mistakes, or faults of others, especially for reasons of expediency	बलि का बकरा
Separable	able to be separated or treated separately	वियोज्य
Stampede	a sudden panicked rush of a number of horses, cattle, or other animals	भगदड़

**SSC MOCK TEST - 409 (ANSWER KEY)**

- |         |         |         |          |
|---------|---------|---------|----------|
| 1. (1)  | 26. (4) | 51. (1) | 76. (4)  |
| 2. (2)  | 27. (2) | 52. (3) | 77. (2)  |
| 3. (4)  | 28. (2) | 53. (3) | 78. (2)  |
| 4. (3)  | 29. (3) | 54. (4) | 79. (3)  |
| 5. (2)  | 30. (4) | 55. (3) | 80. (1)  |
| 6. (1)  | 31. (4) | 56. (2) | 81. (2)  |
| 7. (3)  | 32. (3) | 57. (3) | 82. (4)  |
| 8. (1)  | 33. (2) | 58. (1) | 83. (3)  |
| 9. (4)  | 34. (4) | 59. (2) | 84. (3)  |
| 10. (2) | 35. (2) | 60. (2) | 85. (4)  |
| 11. (2) | 36. (2) | 61. (3) | 86. (3)  |
| 12. (3) | 37. (4) | 62. (4) | 87. (1)  |
| 13. (2) | 38. (4) | 63. (3) | 88. (2)  |
| 14. (1) | 39. (3) | 64. (3) | 89. (4)  |
| 15. (2) | 40. (4) | 65. (2) | 90. (1)  |
| 16. (3) | 41. (1) | 66. (1) | 91. (1)  |
| 17. (2) | 42. (4) | 67. (3) | 92. (3)  |
| 18. (3) | 43. (4) | 68. (4) | 93. (3)  |
| 19. (2) | 44. (1) | 69. (1) | 94. (2)  |
| 20. (4) | 45. (1) | 70. (1) | 95. (2)  |
| 21. (1) | 46. (2) | 71. (4) | 96. (3)  |
| 22. (1) | 47. (3) | 72. (1) | 97. (2)  |
| 23. (2) | 48. (4) | 73. (2) | 98. (4)  |
| 24. (1) | 49. (3) | 74. (4) | 99. (4)  |
| 25. (4) | 50. (2) | 75. (4) | 100. (4) |

76. (4) No error

77. (2) Use 'when' instead of 'then'.

90. (1) The correct spelling of 'Conscinteous' is 'Conscientious', 'Comotion' is 'Commotion' and 'Embarasment' is 'Embarrassment'.

91. (1) The correct spelling of 'Employeeed' is 'Employed' is 'Rehersal' is 'Rehearsal' and 'Seperable' is 'Separable'.